

Model H-380

Relative Humidity / Temperature Probe
and Radiation Shield



The *WATERLOG*[®] Model H-380 Relative Humidity / Temperature Probe combines a high accuracy, capacitance type humidity sensor and temperature sensor in one probe. It is a well proven, accurate and durable sensor.



KEY FEATURES

- Reliable data acquisition and long term calibration-free operation
- Well proven humidity sensor resists condensation and contaminants
- Temperature measurement with precision RTD probe provides fast response and high accuracy
- Linear voltage or current output signals for transmission over long distance
- Operating temperature range of -40° to 85°C
- Fully interchangeable HygroClip module is quickly replaced in the field with no loss of accuracy and no calibration
- Sealed, corrosion-resistant, and nonconductive enclosure
- Digital and analog outputs
- Low heat absorption color



SPECIFICATIONS

Humidity Sensor:	Rotronic Hydromer® C94 (capacitive)
Temperature Sensor:	RTD Pt100 Ohm, 1/3 DIN
Sensor Protection:	Wire mesh filter (standard) / foam filter (optional)
Measuring Range:	0 to 100 % RH and -40° to 185°F (-40° to 85°C)
Accuracy at 23°C (73° F):	±1.5% RH and ±0.3°C / 0.5°- standard calibration
Repeatability:	Better than 0.5% RH and 0.1°F(°C)
Analog Output Signals: (Minimum load > 10 k Ohm)	0 to 100% RH = 0 - 1V -40° to 60°C = 0-1V (-40° to 85°C = 0-1.25V)
Digital Output/Input Signal:	1-wire, HygroClip format, 2-way communication.
Analog Signal Resolution:	0.02% RH and 0.06°C
Digital Signal Resolution:	0.004% RH and 0.004°C
Sampling Time:	< 0.7 seconds
Maximum Cable Length:	15 ft. (5m.) for direct output up to 325 ft. (100m.) with signal amplifier
Connection Type:	Bayonet cap on mounting connector
Protection Grade:	IP65 (probe to connector)
Supply Voltage:	3.5 - 50 VDC
Current Consumption:	< 4mA
Minimum Excitation Time:	< 4 seconds
EMC Compatibility (CE):	EN-50081-2, EN50082-2
Material:	Polycarbonate, white
Dimensions:	Length: 3.94 in. (100mm.) Diameter: 0.59 in. (15mm.)
Weight:	0.5 oz. (14g.)

Radiation Shield: The H-380-SS is a natural aspiration shield. Optimum protection against rainfall and sunshine. Suitable for horizontally incident rain up to 68 km/h.

Construction: UV stabilized white thermoplastic plates aluminum mounting bracket, white stainless steel U-bolt clamp.

Dimensions: 4.7 in. (12cm.) diameter x 10.6 in. (27 cm.) high
Mounting fits vertical pipe 1-2 in. (25 to 50 mm.) diameter.

Weight: Net weight 1.5 lbs. (0.7 kg.)

The probe is a digital humidity temperature plug-in probe with two analog output signals and a one-wire digital output.

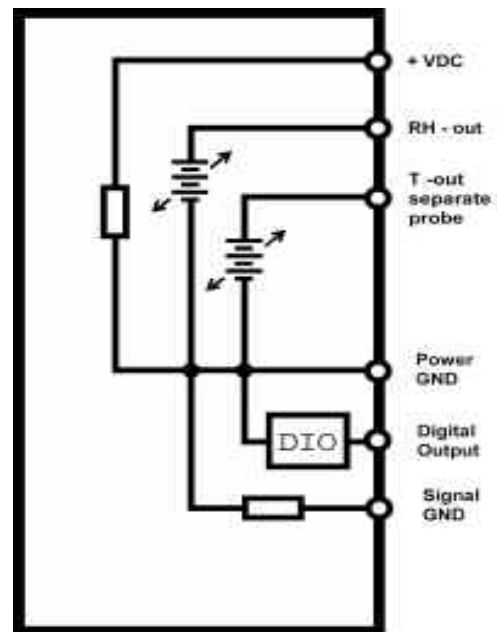

Warranty

The **WATERLOG**® H-380 is warranted against defects in materials and workmanship for one year from date of shipment.

Note

Specifications subject to change without prior notice due to ongoing commitment to product testing and improvement. LR April 11, 2003